

Modele obwodów elektrycznych

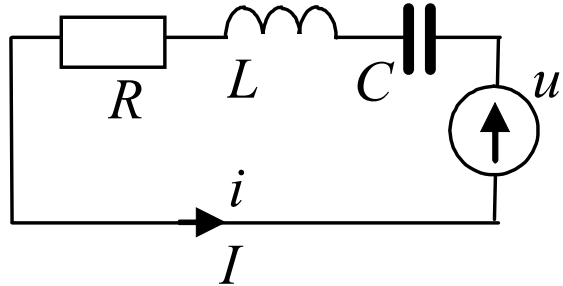

$$(1) \quad j\omega L I + R I + \frac{1}{j\omega C} I = U$$

$$(2) \quad L \frac{di(t)}{dt} + R i(t) + \frac{1}{C} \int i(t) dt = u(t)$$

$$(3) \quad L \ddot{q}(t) + R \dot{q}(t) + \frac{1}{C} q(t) = u(t)$$

$$(4) \quad sL i(s) + R i(s) + \frac{1}{sC} i(s) = u(s)$$

$$(5) \quad i(s) = \frac{sC}{s^2 LC + sRC + 1} u(s)$$

$$u(t) = U \sin(\omega t)$$

$$s = j\omega$$

$$i(t) = \frac{dq(t)}{dt}$$

$$i(t) = I \sin(\omega t + \varphi)$$

$$i(s) = s q(s)$$

Obwody elektryczne

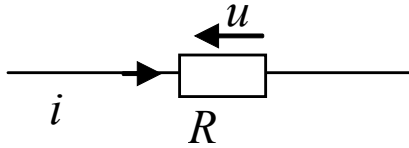

$$u(t) = Ri(t)$$

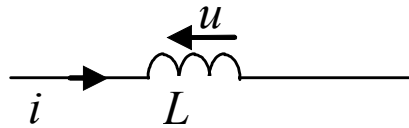

$$u(t) = -L \frac{di(t)}{dt}$$

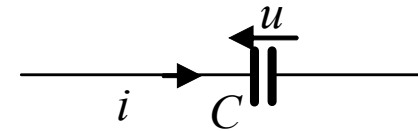

$$u(t) = \frac{1}{C} q(t)$$

$$u(t) = \frac{1}{C} \int i(t) dt$$

Tab. I-6. Stosowane opisy podstawowych elementów elektrycznych

	$u(i)$		$i(u)$	$u(q)$	$Z(s)$
rezystor (R)	$u(t) = Ri(t)$	$u(s) = Ri(s)$	$i(t) = Gu(t)$	$u(t) = R\dot{q}(t)$	R
kondensator (C)	$u(t) = \frac{1}{C} \int i(t) dt$	$u(s) = \frac{1}{sC} i(s)$	$i(t) = C \frac{du(t)}{dt}$	$u(t) = \frac{1}{C} q(t)$	$\frac{1}{sC}$
cewka (L)	$e_L(t) = -L \frac{di(t)}{dt}$	$u(s) = sLi(s)$	$i(t) = \frac{1}{L} \int u(t) dt$	$u(t) = L\ddot{q}(t)$	sL

$$i(t) = \frac{dq(t)}{dt}$$

$$i(s) = sq(s)$$

Obwody elektryczne

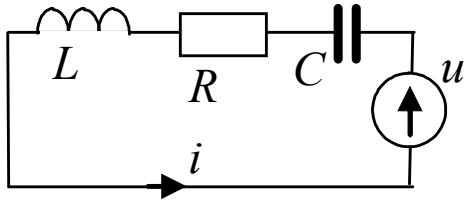

$$j\omega LI + RI + \frac{1}{j\omega C} I = U$$

$$sLi(s) + Ri(s) + \frac{1}{sC} i(s) = u(s)$$

$$L \frac{di(t)}{dt} + Ri(t) + \frac{1}{C} \int i(t) dt = u(t)$$

$$L\ddot{q}(t) + R\dot{q}(t) + \frac{1}{C} q(t) = u(t)$$

$$q(s) = \left(\frac{C}{s^2 LC + sRC + 1} \right) u(s)$$

$$i(s) = \left(\frac{sC}{s^2 LC + sRC + 1} \right) u(s)$$

$$i(s) = sq(s)$$

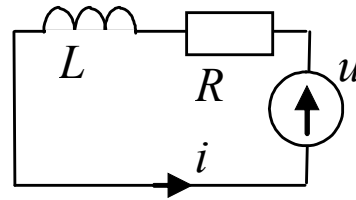

$$L \frac{di(t)}{dt} + Ri(t) = u(t)$$

$$sLi(s) + Ri(s) = u(s)$$

$$i(s) = \left(\frac{1}{sL + R} \right) u(s)$$

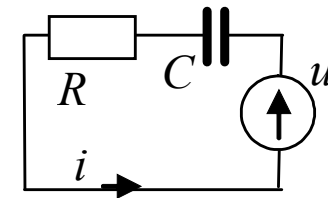

$$Ri(t) + \frac{1}{C} \int i(t) dt = u(t)$$

$$Ri(s) + \frac{1}{sC} i(s) = u(s)$$

$$i(s) = \left(\frac{sC}{sRC + 1} \right) u(s)$$

$$R\dot{q}(t) + \frac{1}{C} q(t) = u(t)$$

$$sRq(t) + \frac{1}{C} q(t) = u(t)$$

$$q(s) = \left(\frac{C}{sCR + 1} \right) u(s)$$

Obwody elektryczne

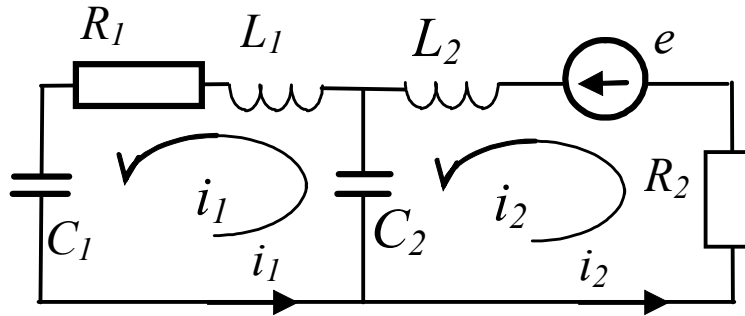

$$\begin{cases} e = L_2 \frac{di_2}{dt} + R_2 i_2 + \int \frac{i_2 - i_1}{C_2} dt \\ 0 = L_1 \frac{di_1}{dt} + R_1 i_1 + \int \frac{i_1}{C_1} dt + \int \frac{i_1 - i_2}{C_2} dt \end{cases}$$

$$\begin{cases} e = sL_2 i_2 + R_2 i_2(s) + \frac{i_2 - i_1}{sC_2} \\ 0 = sL_1 i_1 + R_1 i_1 + \frac{i_1}{sC_1} + \frac{i_1 - i_2}{sC_2} \end{cases} \quad \text{rząd?}$$

$$\begin{cases} e = L_2 \ddot{q}_2 + R_2 \dot{q}_2 + \frac{q_2 - q_1}{C_2} \\ 0 = L_1 \ddot{q}_1 + R_1 \dot{q}_1 + \frac{q_1}{C_1} + \frac{q_1 - q_2}{C_2} \end{cases}$$

$$\begin{cases} sC_2 e = M_2 i_2 - i_1 \\ 0 = M_1 i_1 - C_1 i_2 \end{cases}$$

$$\begin{cases} C_2 e = M_2 q_2 - q_1 \\ 0 = M_1 q_1 - C_1 q_2 \end{cases}$$

$$M_2 = s^2 C_2 L_2 + sC_2 R_2 s + 1$$

$$M_1 = s^2 C_1 C_2 L_1 + sC_1 C_2 R_1 + C_2 + C_1$$

$$i_1 = \frac{sC_1 C_2}{M_1 M_2 - C_1} e$$

$$q_1 = \frac{C_1 C_2}{M_1 M_2 - C_1} e$$

$$i_2 = \frac{sC_2 M_1}{M_1 M_2 - C_1} e$$

$$\boxed{i(s) = s q(s)}$$

$$q_2 = \frac{C_2 M_1}{M_1 M_2 - C_1} e$$

Obwody elektryczne - czwórniki

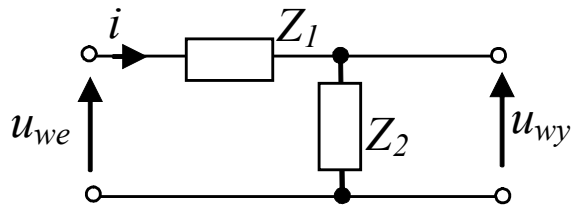

$$\begin{cases} u_{we} = (Z_1 + Z_2)i \\ u_{wy} = Z_2 i \end{cases}$$

$$u_{wy} = \left(\frac{Z_2}{Z_1 + Z_2} \right) u_{we}$$

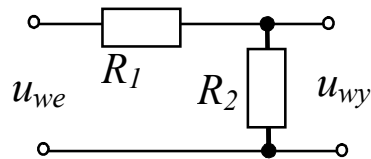

$$u_{wy}(s) = \left(\frac{R_2}{R_1 + R_2} \right) u_{we}(s)$$

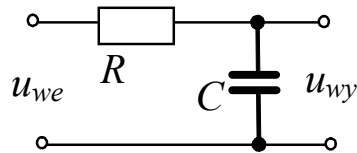

$$\begin{aligned} Z_1 &= R \\ Z_2 &= 1/sC \end{aligned}$$

$$u_{wy}(s) = \left(\frac{1}{sCR + 1} \right) u_{we}(s)$$

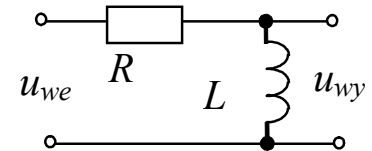

$$\begin{aligned} Z_1 &= R \\ Z_2 &= sL \end{aligned}$$

$$u_{wy}(s) = \left(\frac{sL}{sL + R} \right) u_{we}(s)$$

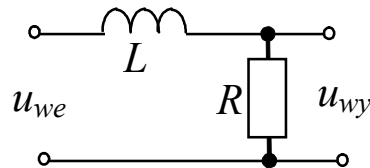

$$u_{wy}(s) = \left(\frac{R}{sL + R} \right) u_{we}(s)$$

Obwody elektryczne – wzmacniacze operacyjne

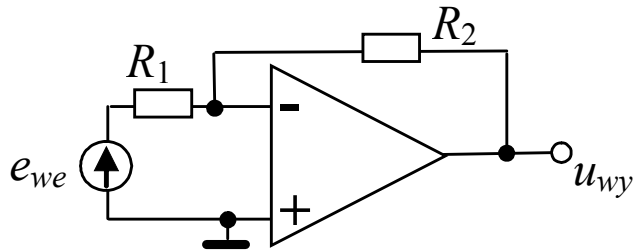

$$u_{wy} = \frac{-Z_2}{Z_1} e_{we}$$

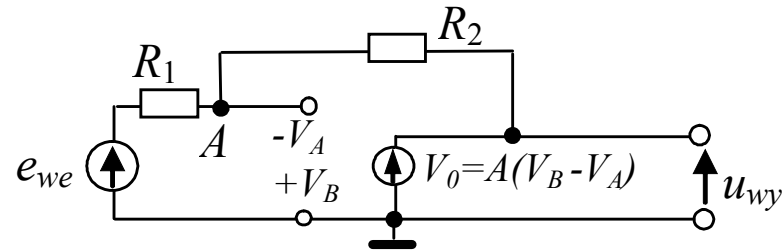

$$\begin{cases} \frac{V_A - e_{we}}{R_1} = \frac{V_0 - V_A}{R_2} \\ u_{wy} = V_0 = A(V_B - V_A) = -AV_A \end{cases}$$

$$u_{wy} = \frac{-R_2}{R_1 + \frac{R_1 + R_2}{A}} e_{we} \xrightarrow{A \rightarrow \infty} u_{wy} = \frac{-R_2}{R_1} e_{we}$$

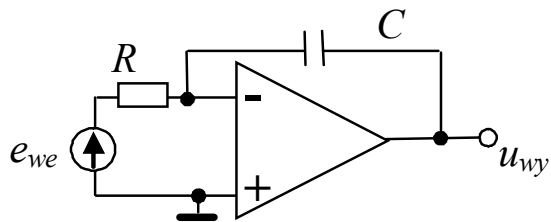

$$\begin{aligned} Z_1 &= R \\ Z_2 &= 1/sC \end{aligned}$$

$$u_{wy} = \frac{-1}{sRC} e_{we}$$

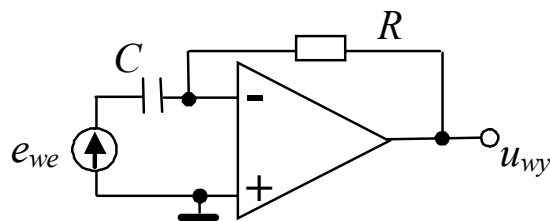

$$\begin{aligned} Z_1 &= 1/sC \\ Z_2 &= R \end{aligned}$$

$$u_{wy} = -sRC e_{we}$$

Układy mechaniczne

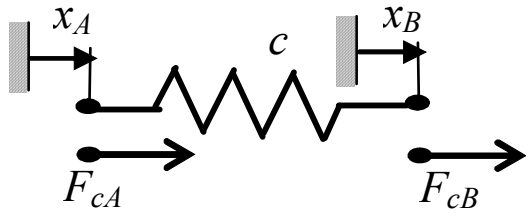

$$F_{cA}(t) = c(x_A(t) - x_B(t))$$

$$F_{cB}(t) = c(x_B(t) - x_A(t))$$

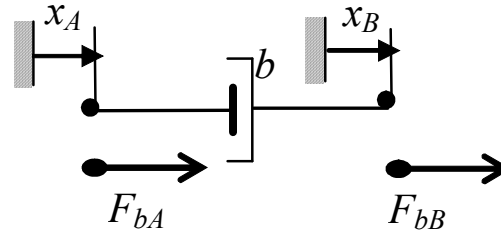

$$F_{bA}(t) = b(\dot{x}_A(t) - \dot{x}_B(t))$$

$$F_{bB}(t) = b(\dot{x}_B(t) - \dot{x}_A(t))$$

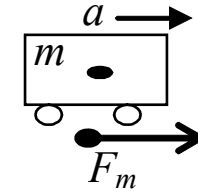

$$F_m(t) = m\ddot{x}(t)$$

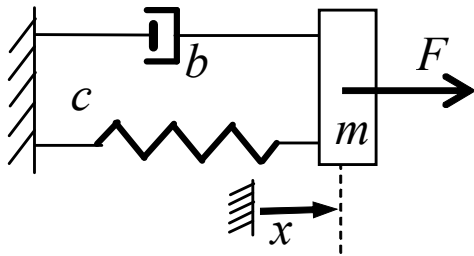

$$m\ddot{x}(t) + b\dot{x}(t) + cx(t) = F(t)$$

$$ms^2x(s) + bsx(s) + cx(s) = F(s)$$

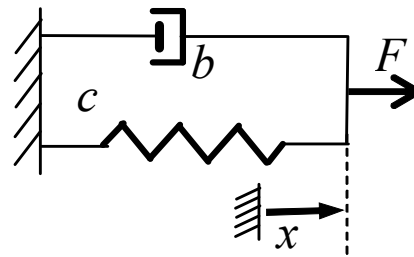

$$b\dot{x}(t) + cx(t) = F(t)$$

$$bsx(s) + cx(s) = F(s)$$

$$x(s) = \left(\frac{1}{sb + c} \right) F(s)$$

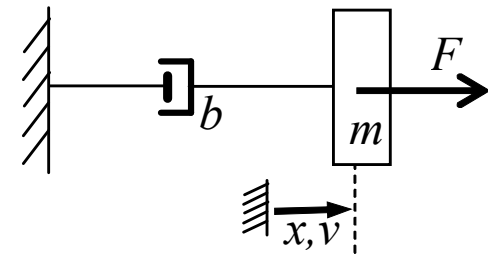

$$m\ddot{x}(t) + b\dot{x}(t) = F(t)$$

$$m\dot{v}(t) + bv(t) = F(t)$$

$$v(s) = \left(\frac{1}{sm + b} \right) F(s)$$

Układy mechaniczne

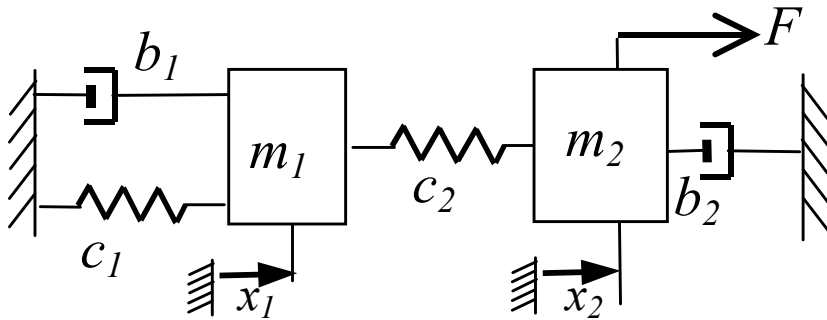

$$\begin{cases} F = m_2 \ddot{x}_2 + b_2 \dot{x}_2 + c_2 (x_2 - x_1) \\ 0 = m_1 \ddot{x}_1 + b_1 \dot{x}_1 + c_1 x_1 + c_2 (x_1 - x_2) \end{cases}$$

$$\begin{cases} F = s^2 m_2 x_2 + s b_2 x_2 + c_2 (x_2 - x_1) \\ 0 = s^2 m_1 x_1 + s b_1 x_1 + c_1 x_1 + c_2 (x_1 - x_2) \end{cases}$$